



Republic of the Philippines
PHILIPPINE ECONOMIC ZONE AUTHORITY
Cavite Economic Zone, Rosario Cavite

**APPLICATION OF REFLECTORIZED
THERMOPLASTIC PAINT AT ROAD
CENTERLINES, PEDESTRIAN LANES,
YELLOW LANES, INTERSECTIONS, AND
ROAD HUMPS ALONG CEZ MAIN AND
MAJOR SECONDARY ROADS
(CEZITB 2021-04-008)**

April 2021

Sixth Edition

TABLE OF CONTENTS

GLOSSARY OF.....	4
TERMS, ABBREVIATIONS, AND ACRONYMS	4
SECTION I. INVITATION TO BID.....	7
SECTION II. INSTRUCTIONS TO BIDDERS	9
1. Scope of Bid.....	10
2. Funding Information	10
3. Bidding Requirements.....	10
4. Corrupt, Fraudulent, Collusive, Coercive, and Obstructive Practices	10
5. Eligible Bidders.....	11
6. Origin of Associated Goods	11
7. Subcontracts	11
8. Pre-Bid Conference	11
9. Clarification and Amendment of Bidding Documents.....	11
10. Documents Comprising the Bid: Eligibility and Technical Components.....	12
11. Documents Comprising the Bid: Financial Component	12
12. Alternative Bids	12
13. Bid Prices	13
14. Bid and Payment Currencies.....	13
15. Bid Security.....	13
16. Sealing and Marking of Bids.....	13
17. Deadline for Submission of Bids	14
18. Opening and Preliminary Examination of Bids	14
19. Detailed Evaluation and Comparison of Bids	14
20. Post Qualification.....	14
21. Signing of the Contract	15
SECTION III. BID DATA SHEET	16
SECTION IV. GENERAL CONDITIONS OF CONTRACT	19
1. Scope of Contract.....	20
2. Sectional Completion of Works	20
3. Possession of Site.....	20
4. The Contractor’s Obligations.....	20
5. Performance Security	21

6.	Site Investigation Reports	21
7.	Warranty.....	21
8.	Liability of the Contractor.....	21
9.	Termination for Other Causes	21
10.	Dayworks	22
11.	Program of Work.....	22
12.	Instructions, Inspections and Audits	22
13.	Advance Payment.....	22
14.	Progress Payments	22
15.	Operating and Maintenance Manuals.....	22
SECTION V. SPECIAL CONDITIONS OF CONTRACT		24
SECTION VI. SPECIFICATIONS.....		26
SECTION VII. DRAWINGS		30
SECTION VIII. BILL OF QUANTITIES		31
SECTION IX. CHECKLIST OF TECHNICAL AND FINANCIAL DOCUMENTS		32

Glossary of Terms, Abbreviations, and Acronyms

ABC – Approved Budget for the Contract.

ARCC – Allowable Range of Contract Cost.

BAC – Bids and Awards Committee.

Bid – A signed offer or proposal to undertake a contract submitted by a bidder in response to and in consonance with the requirements of the bidding documents. Also referred to as *Proposal* and *Tender*. (2016 revised IRR, Section 5[c])

Bidder – Refers to a contractor, manufacturer, supplier, distributor and/or consultant who submits a bid in response to the requirements of the Bidding Documents. (2016 revised IRR, Section 5[d])

Bidding Documents – The documents issued by the Procuring Entity as the bases for bids, furnishing all information necessary for a prospective bidder to prepare a bid for the Goods, Infrastructure Projects, and/or Consulting Services required by the Procuring Entity. (2016 revised IRR, Section 5[e])

BIR – Bureau of Internal Revenue.

BSP – Bangko Sentral ng Pilipinas.

CDA – Cooperative Development Authority.

Consulting Services – Refer to services for Infrastructure Projects and other types of projects or activities of the GOP requiring adequate external technical and professional expertise that are beyond the capability and/or capacity of the GOP to undertake such as, but not limited to: (i) advisory and review services; (ii) pre-investment or feasibility studies; (iii) design; (iv) construction supervision; (v) management and related services; and (vi) other technical services or special studies. (2016 revised IRR, Section 5[i])

Contract – Refers to the agreement entered into between the Procuring Entity and the Supplier or Manufacturer or Distributor or Service Provider for procurement of Goods and Services; Contractor for Procurement of Infrastructure Projects; or Consultant or Consulting Firm for Procurement of Consulting Services; as the case may be, as recorded in the Contract Form signed by the parties, including all attachments and appendices thereto and all documents incorporated by reference therein.

Contractor – is a natural or juridical entity whose proposal was accepted by the Procuring Entity and to whom the Contract to execute the Work was awarded. Contractor as used in these Bidding Documents may likewise refer to a supplier, distributor, manufacturer, or consultant.

CPI – Consumer Price Index.

DOLE – Department of Labor and Employment.

DTI – Department of Trade and Industry.

Foreign-funded Procurement or Foreign-Assisted Project – Refers to procurement whose funding source is from a foreign government, foreign or international financing institution as specified in the Treaty or International or Executive Agreement. (2016 revised IRR, Section 5[b]).

GFI – Government Financial Institution.

GOCC – Government-owned and/or –controlled corporation.

Goods – Refer to all items, supplies, materials and general support services, except Consulting Services and Infrastructure Projects, which may be needed in the transaction of public businesses or in the pursuit of any government undertaking, project or activity, whether in the nature of equipment, furniture, stationery, materials for construction, or personal property of any kind, including non-personal or contractual services such as the repair and maintenance of equipment and furniture, as well as trucking, hauling, janitorial, security, and related or analogous services, as well as procurement of materials and supplies provided by the Procuring Entity for such services. The term “related” or “analogous services” shall include, but is not limited to, lease or purchase of office space, media advertisements, health maintenance services, and other services essential to the operation of the Procuring Entity. (2016 revised IRR, Section 5[r])

GOP – Government of the Philippines.

Infrastructure Projects – Include the construction, improvement, rehabilitation, demolition, repair, restoration or maintenance of roads and bridges, railways, airports, seaports, communication facilities, civil works components of information technology projects, irrigation, flood control and drainage, water supply, sanitation, sewerage and solid waste management systems, shore protection, energy/power and electrification facilities, national buildings, school buildings, hospital buildings, and other related construction projects of the government. Also referred to as *civil works or works*. (2016 revised IRR, Section 5[u])

LGUs – Local Government Units.

NFCC – Net Financial Contracting Capacity.

NGA – National Government Agency.

PCAB – Philippine Contractors Accreditation Board.

PhilGEPS - Philippine Government Electronic Procurement System.

Procurement Project – refers to a specific or identified procurement covering goods, infrastructure project or consulting services. A Procurement Project shall be described, detailed, and scheduled in the Project Procurement Management Plan prepared by the agency which shall be consolidated in the procuring entity's Annual Procurement Plan. (GPPB Circular No. 06-2019 dated 17 July 2019)

PSA – Philippine Statistics Authority.

SEC – Securities and Exchange Commission.

SLCC – Single Largest Completed Contract.

UN – United Nations.

Section I. Invitation to Bid

APPLICATION OF REFLECTORIZED THERMOPLASTIC PAINT AT ROAD CENTERLINES, PEDESTRIAN LANES, YELLOW LANES, INTERSECTIONS, AND ROAD HUMPS ALONG CEZ MAIN AND MAJOR SECONDARY ROADS (CEZITB 2021-04-008)

1. The *PHILIPPINE ECONOMIC ZONE AUTHORITY-CAVITE ECONOMIC ZONE (PEZA-CEZ)*, through the *Corporate Operating Budget for CY 2021* intends to apply the sum of **Pesos: Three Million Five Hundred Eighty One Thousand Two Hundred Fifty Seven and 11/100 Only (₱3,581,257.11)** being the Approved Budget for the Contract (ABC) to payments under the contract for the ***Application of ReflectORIZED Thermoplastic Paint at Road Centerlines, Pedestrian Lanes, Yellow Lanes, Intersections, and Road Humps along CEZ Main and Major Secondary Roads (CEZITB 2021-04-008)***. Bids received in excess of the ABC shall be automatically rejected at bid opening.
2. The *PEZA-CEZ* now invites bids for the above Procurement Project. Completion of the Works is required within ***thirty (30) calendar days***. Bidders should have completed, within ***the last five (5) years*** from the date of submission and receipt of bids, a contract similar to the Project. The description of an eligible bidder is contained in the Bidding Documents, particularly, in Section II (Instructions to Bidders).
3. Bidding will be conducted through open competitive bidding procedures using non-discretionary “*pass/fail*” criterion as specified in the 2016 revised Implementing Rules and Regulations (IRR) of Republic Act (RA) No. 9184.

Bidding is restricted to Filipino citizens/sole proprietorships, cooperatives, and partnerships, or organizations with at least seventy five percent (75%) interest or outstanding capital stock belonging to citizens of the Philippines.

4. Interested bidders may obtain further information from ***CEZ-BAC Secretariat*** and inspect the Bidding Documents at the address given below from ***Monday to Friday from 8:00 a.m. to 5:00 p.m.***
5. A complete set of Bidding Documents may be acquired by interested bidders on ***21 April 2021*** from the given address and website/s below *and upon payment of the applicable fee for the Bidding Documents, pursuant to the latest Guidelines issued by the GPPB, in the amount of **Five Thousand Pesos Only (₱5,000.00)***. The Procuring Entity shall allow the bidder to present its proof of payment for the fees *in person*.
6. The *PEZA-CEZ* will hold a Pre-Bid Conference on ***29 April 2021, 2:30pm*** at ***2nd Floor, Function Room, New Administration Building, Cavite Economic Zone, Rosario, Cavite, and/or through videoconferencing / webcasting via Microsoft Teams***, which shall be open to prospective bidders. For bidders who

wish not to be physically present during the pre-bid conference, the BAC Secretariat shall email invite/meeting ID and password to those who signify their intent via email below.

7. Bids must be duly received by the BAC Secretariat through (i) manual submission at the office address as indicated below, on or before **2:00pm, 11 May 2021**. Late bids shall not be accepted.
8. All bids must be accompanied by a bid security in any of the acceptable forms and in the amount stated in **ITB** Clause 16.
9. Bid opening shall be on **11 May 2021, 2:30pm** at the given address below. Bids will be opened in the presence of the bidders' representatives who choose to attend the activity.
10. In any case the above dates is declared a special non-working holiday, it will automatically be reset on the next working day.
11. The *PEZA-CEZ* reserves the right to reject any and all bids, declare a failure of bidding, or not award the contract at any time prior to contract award in accordance with Sections 35.6 and 41 of the 2016 revised Implementing Rules and Regulations (IRR) of RA No. 9184, without thereby incurring any liability to the affected bidder or bidders.
12. For further information, please refer to:

Secretariat, CEZ-Bids and Awards Committee
Phil. Economic Zone Authority-Cavite Economic Zone
2/F New Administration Bldg., CEZ, Rosario, Cavite
Tel. Nos. (046) 4376146 / 4376070
Tel./Fax No. (046) 437-6090
Email: cezbac@peza.gov.ph

13. You may visit the following websites:

For downloading of Bidding Documents:

- a. PEZA Website (<http://www.peza.gov.ph/index.php/bid-opportunities>); or
- b. Philgeps Website

16 March 2021

LEVI D. VIZMANOS
Chairperson, CEZ-BAC

Section II. Instructions to Bidders

1. Scope of Bid

The Procuring Entity, *PEZA-Cavite Economic Zone* invites Bids for the *Application of Reflectorized Thermoplastic Paint at Road Centerlines, Pedestrian Lanes, Yellow Lanes, Intersections, and Road Humps along CEZ Main and Major Secondary Roads*, with Project Identification Number *CEZITB 2021-04-008*.

The Procurement Project (referred to herein as “Project”) is for the construction of Works, as described in Section VI (Specifications).

2. Funding Information

2.1. The GOP through the source of funding as indicated below for *Corporate Operating Budget for CY 2021* in the amount of *Pesos: Three Million Five Hundred Eighty-One Thousand Two Hundred Fifty-Seven and 11/100 Only (₱3,581,257.11)*.

2.2. The source of funding is:

- a. GOCC, the Corporate Operating Budget.

3. Bidding Requirements

The Bidding for the Project shall be governed by all the provisions of RA No. 9184 and its 2016 revised IRR, including its Generic Procurement Manual and associated policies, rules and regulations as the primary source thereof, while the herein clauses shall serve as the secondary source thereof.

Any amendments made to the IRR and other GPPB issuances shall be applicable only to the ongoing posting, advertisement, or invitation to bid by the BAC through the issuance of a supplemental or bid bulletin.

The Bidder, by the act of submitting its Bid, shall be deemed to have inspected the site, determined the general characteristics of the contracted Works and the conditions for this Project, such as the location and the nature of the work; (b) climatic conditions; (c) transportation facilities; (c) nature and condition of the terrain, geological conditions at the site communication facilities, requirements, location and availability of construction aggregates and other materials, labor, water, electric power and access roads; and (d) other factors that may affect the cost, duration and execution or implementation of the contract, project, or work and examine all instructions, forms, terms, and project requirements in the Bidding Documents.

4. Corrupt, Fraudulent, Collusive, Coercive, and Obstructive Practices

The Procuring Entity, as well as the Bidders and Contractors, shall observe the highest standard of ethics during the procurement and execution of the contract. They or through an agent shall not engage in corrupt, fraudulent, collusive, coercive, and obstructive practices defined under Annex “I” of the 2016 revised IRR of RA No. 9184 or other integrity violations in competing for the Project.

5. Eligible Bidders

- 5.1. Only Bids of Bidders found to be legally, technically, and financially capable will be evaluated.
- 5.2. The Bidder must have an experience of having completed a Single Largest Completed Contract (SLCC) that is similar to this Project, equivalent to at least fifty percent (50%) of the ABC adjusted, if necessary, by the Bidder to current prices using the PSA's CPI, except under conditions provided for in Section 23.4.2.4 of the 2016 revised IRR of RA No. 9184.

A contract is considered to be "similar" to the contract to be bid if it has the major categories of work stated in the **BDS**.

- 5.3. For Foreign-funded Procurement, the Procuring Entity and the foreign government/foreign or international financing institution may agree on another track record requirement, as specified in the Bidding Document prepared for this purpose.
- 5.4. The Bidders shall comply with the eligibility criteria under Section 23.4.2 of the 2016 IRR of RA No. 9184.

6. Origin of Associated Goods

There is no restriction on the origin of Goods other than those prohibited by a decision of the UN Security Council taken under Chapter VII of the Charter of the UN.

7. Subcontracts

- 7.1. The Bidder may subcontract portions of the Project to the extent allowed by the Procuring Entity as stated herein, but in no case more than fifty percent (50%) of the Project.
 - a. Subcontracting is not allowed.

8. Pre-Bid Conference

The Procuring Entity will hold a pre-bid conference for this Project on **29 April 2021, 2:30pm** and either at its physical address **at 2F Function Room, New Admin Building, CEZ Rosario Cavite** and/or through videoconferencing/webcasting} as indicated in paragraph 6 of the **IB**.

9. Clarification and Amendment of Bidding Documents

Prospective bidders may request for clarification on and/or interpretation of any part of the Bidding Documents. Such requests must be in writing and received by the Procuring Entity, either at its given address or through electronic mail indicated in the **IB**, at least ten (10) calendar days before the deadline set for the submission and receipt of Bids.

10. Documents Comprising the Bid: Eligibility and Technical Components

- 10.1. The first envelope shall contain the eligibility and technical documents of the Bid as specified in **Section IX. Checklist of Technical and Financial Documents**.
- 10.2. If the eligibility requirements or statements, the bids, and all other documents for submission to the BAC are in foreign language other than English, it must be accompanied by a translation in English, which shall be authenticated by the appropriate Philippine foreign service establishment, post, or the equivalent office having jurisdiction over the foreign bidder's affairs in the Philippines. For Contracting Parties to the Apostille Convention, only the translated documents shall be authenticated through an apostille pursuant to GPPB Resolution No. 13-2019 dated 23 May 2019. The English translation shall govern, for purposes of interpretation of the bid.
- 10.3. A valid PCAB License is required, and in case of joint ventures, a valid special PCAB License, and registration for the type and cost of the contract for this Project. Any additional type of Contractor license or permit shall be indicated in the **BDS**.
- 10.4. A List of Contractor's key personnel (e.g., Project Manager, Project Engineers, Materials Engineers, and Foremen) assigned to the contract to be bid, with their complete qualification and experience data shall be provided. These key personnel must meet the required minimum years of experience set in the **BDS**.
- 10.5. A List of Contractor's major equipment units, which are owned, leased, and/or under purchase agreements, supported by proof of ownership, certification of availability of equipment from the equipment lessor/vendor for the duration of the project, as the case may be, must meet the minimum requirements for the contract set in the **BDS**.

11. Documents Comprising the Bid: Financial Component

- 11.1. The second bid envelope shall contain the financial documents for the Bid as specified in **Section IX. Checklist of Technical and Financial Documents**.
- 11.2. Any bid exceeding the ABC indicated in paragraph 1 of the **IB** shall not be accepted.
- 11.3. For Foreign-funded procurement, a ceiling may be applied to bid prices provided the conditions are met under Section 31.2 of the 2016 revised IRR of RA No. 9184.

12. Alternative Bids

Bidders shall submit offers that comply with the requirements of the Bidding Documents, including the basic technical design as indicated in the drawings and

specifications. Unless there is a value engineering clause in the **BDS**, alternative Bids shall not be accepted.

13. Bid Prices

All bid prices for the given scope of work in the Project as awarded shall be considered as fixed prices, and therefore not subject to price escalation during contract implementation, except under extraordinary circumstances as determined by the NEDA and approved by the GPPB pursuant to the revised Guidelines for Contract Price Escalation guidelines.

14. Bid and Payment Currencies

14.1. Bid prices may be quoted in the local currency or tradeable currency accepted by the BSP at the discretion of the Bidder. However, for purposes of bid evaluation, Bids denominated in foreign currencies shall be converted to Philippine currency based on the exchange rate as published in the BSP reference rate bulletin on the day of the bid opening.

14.2. *Payment of the contract price shall be made in:*

- a. Philippine Pesos.

15. Bid Security

15.1. The Bidder shall submit a Bid Securing Declaration or any form of Bid Security in the amount indicated in the **BDS**, which shall be not less than the percentage of the ABC in accordance with the schedule in the **BDS**.

15.2. The Bid and bid security shall be valid until **One Hundred Twenty (120) calendar days from the date of opening of bids**. Any bid not accompanied by an acceptable bid security shall be rejected by the Procuring Entity as non-responsive.

16. Sealing and Marking of Bids

Each Bidder shall submit two (2) copies of the first and second components of its Bid. (Original and Copy 1)

The Procuring Entity may request additional hard copies and/or electronic copies of the Bid. However, failure of the Bidders to comply with the said request shall not be a ground for disqualification.

If the Procuring Entity allows the submission of bids through online submission to the given website or any other electronic means, the Bidder shall submit an electronic copy of its Bid, which must be digitally signed. An electronic copy that cannot be opened or is corrupted shall be considered non-responsive and, thus, automatically disqualified.

17. **Deadline for Submission of Bids**

The Bidders shall submit on the specified date and time and either at its physical address or through online submission as indicated in paragraph 7 of the **IB**.

2:00pm, 11 May 2021 through manual submission

18. **Opening and Preliminary Examination of Bids**

18.1. The BAC shall open the Bids in public at the time, on the date, and at the place specified in paragraph 9 of the **IB**. The Bidders' representatives who are present shall sign a register evidencing their attendance. In case videoconferencing, webcasting or other similar technologies will be used, attendance of participants shall likewise be recorded by the BAC Secretariat.

In case the Bids cannot be opened as scheduled due to justifiable reasons, the rescheduling requirements under Section 29 of the 2016 revised IRR of RA No. 9184 shall prevail.

18.2. The preliminary examination of Bids shall be governed by Section 30 of the 2016 revised IRR of RA No. 9184.

19. **Detailed Evaluation and Comparison of Bids**

19.1. The Procuring Entity's BAC shall immediately conduct a detailed evaluation of all Bids rated "*passed*" using non-discretionary pass/fail criteria. The BAC shall consider the conditions in the evaluation of Bids under Section 32.2 of 2016 revised IRR of RA No. 9184.

19.2. If the Project allows partial bids, all Bids and combinations of Bids as indicated in the **BDS** shall be received by the same deadline and opened and evaluated simultaneously so as to determine the Bid or combination of Bids offering the lowest calculated cost to the Procuring Entity. Bid Security as required by **ITB** Clause 16 shall be submitted for each contract (lot) separately.

19.3. In all cases, the NFCC computation pursuant to Section 23.4.2.6 of the 2016 revised IRR of RA No. 9184 must be sufficient for the total of the ABCs for all the lots participated in by the prospective Bidder.

20. **Post Qualification**

Within a non-extendible period of five (5) calendar days from receipt by the Bidder of the notice from the BAC that it submitted the Lowest Calculated Bid, the Bidder shall submit its latest income and business tax returns filed and paid through the BIR Electronic Filing and Payment System (eFPS), and other appropriate licenses and permits required by law and stated in the **BDS**.

21. Signing of the Contract

The documents required in Section 37.2 of the 2016 revised IRR of RA No. 9184 shall form part of the Contract. Additional Contract documents are indicated in the **BDS**.

Section III. Bid Data Sheet

Bid Data Sheet

ITB Clause																
5.2	<p>For this purpose, contracts similar to the Project refer to contracts which have the same major categories of work, which shall be:</p> <p style="margin-left: 40px;">1) <i>Concrete or asphalt road project with thermoplastic marking application;</i></p> <p style="margin-left: 40px;">2) <i>Completed within five (5) years prior to the deadline for the submission and receipt of bids.</i></p>															
7.1	Subcontracting is not allowed.															
10.3	<p><i>valid PCAB License</i></p> <p style="margin-left: 40px;">a. Size Range: <u>Small B</u></p> <p style="margin-left: 40px;">b. License Category: <u>C & D</u></p> <p style="margin-left: 40px;">c. Allowable Range of Contract Cost: <u>up to 30M</u></p>															
10.4	<p>The key personnel must meet the required minimum years of experience set below:</p> <table border="1" style="width: 100%; border-collapse: collapse; margin-top: 10px;"> <thead> <tr style="background-color: #fff9c4;"> <th style="text-align: center;">Key Personnel</th> <th style="text-align: center;">General Experience (Years)</th> <th style="text-align: center;">Relevant Experience (Years)</th> </tr> </thead> <tbody> <tr> <td>Project Manager</td> <td style="text-align: center;">5</td> <td style="text-align: center;">3</td> </tr> <tr> <td>Project Engineer</td> <td style="text-align: center;">5</td> <td style="text-align: center;">3</td> </tr> <tr> <td>Construction Foreperson (Foreman)</td> <td style="text-align: center;">5</td> <td style="text-align: center;">3</td> </tr> <tr> <td>Safety Officer</td> <td style="text-align: center;">5</td> <td style="text-align: center;">2</td> </tr> </tbody> </table>	Key Personnel	General Experience (Years)	Relevant Experience (Years)	Project Manager	5	3	Project Engineer	5	3	Construction Foreperson (Foreman)	5	3	Safety Officer	5	2
Key Personnel	General Experience (Years)	Relevant Experience (Years)														
Project Manager	5	3														
Project Engineer	5	3														
Construction Foreperson (Foreman)	5	3														
Safety Officer	5	2														
10.5	<p>The minimum major equipment requirements are the following:</p> <table border="1" style="width: 100%; border-collapse: collapse; margin-top: 10px;"> <thead> <tr style="background-color: #fff9c4;"> <th style="text-align: center;">Equipment</th> <th style="text-align: center;">Number of Units</th> <th style="text-align: center;">Minimum Capacity</th> </tr> </thead> <tbody> <tr> <td>Electric chipping hammer</td> <td style="text-align: center;">1</td> <td style="text-align: center;">105-140 bar</td> </tr> <tr> <td>Generator set</td> <td style="text-align: center;">1</td> <td style="text-align: center;">6 KVa</td> </tr> <tr> <td>Welding Machine</td> <td style="text-align: center;">1</td> <td style="text-align: center;">200 - 400 amp</td> </tr> </tbody> </table>	Equipment	Number of Units	Minimum Capacity	Electric chipping hammer	1	105-140 bar	Generator set	1	6 KVa	Welding Machine	1	200 - 400 amp			
Equipment	Number of Units	Minimum Capacity														
Electric chipping hammer	1	105-140 bar														
Generator set	1	6 KVa														
Welding Machine	1	200 - 400 amp														
12	<i>Value Engineering not allowed.]</i>															

15.1	<p>The bid security shall be in the form of a Bid Securing Declaration or any of the following forms and amounts:</p> <p>a. The amount of not less than ₱ 71,625.14, if bid security is in cash, cashier's/manager's check, bank draft/guarantee or irrevocable letter of credit;</p> <p>b. The amount of not less than ₱ 179,062.86, if bid security is in Surety Bond.</p>
19.2	<p>Partial bid is not allowed. The infrastructure project is packaged in a single lot and the lot shall not be divided into sub-lots for the purpose of bidding, evaluation, and contract award.</p>
20	<p><i>a. Bidder with the LCB shall submit income and business tax returns filed through the Electronic Filing and Payments System (EFPS). The latest income and business tax returns are those within the last six months preceding the date of bid submission. (To be submitted by the LCRB)</i></p>
21	<p>Additional contract documents relevant to the Project that may be required by existing laws and/or the Procuring Entity, such as:</p> <ol style="list-style-type: none"> <i>1. Certificate of Site Inspection issued by the CEZ Engineering & Maintenance Division. (To be included in the Eligibility / Technical Envelope (Bid Opening)).</i> <i>2. Construction schedule and S-curve, Manpower schedule, Construction methods, Equipment utilization schedule, Construction Safety and Health Program approved by the DOLE, and other acceptable tools of project scheduling. (To be submitted by the LCRB)</i>

Section IV. General Conditions of Contract

1. Scope of Contract

This Contract shall include all such items, although not specifically mentioned, that can be reasonably inferred as being required for its completion as if such items were expressly mentioned herein. All the provisions of RA No. 9184 and its 2016 revised IRR, including the Generic Procurement Manual, and associated issuances, constitute the primary source for the terms and conditions of the Contract, and thus, applicable in contract implementation. Herein clauses shall serve as the secondary source for the terms and conditions of the Contract.

This is without prejudice to Sections 74.1 and 74.2 of the 2016 revised IRR of RA No. 9184 allowing the GPPB to amend the IRR, which shall be applied to all procurement activities, the advertisement, posting, or invitation of which were issued after the effectivity of the said amendment.

2. Sectional Completion of Works

If sectional completion is specified in the **Special Conditions of Contract (SCC)**, references in the Conditions of Contract to the Works, the Completion Date, and the Intended Completion Date shall apply to any Section of the Works (other than references to the Completion Date and Intended Completion Date for the whole of the Works).

3. Possession of Site

4.1. The Procuring Entity shall give possession of all or parts of the Site to the Contractor based on the schedule of delivery indicated in the **SCC**, which corresponds to the execution of the Works. If the Contractor suffers delay or incurs cost from failure on the part of the Procuring Entity to give possession in accordance with the terms of this clause, the Procuring Entity's Representative shall give the Contractor a Contract Time Extension and certify such sum as fair to cover the cost incurred, which sum shall be paid by Procuring Entity.

4.2. If possession of a portion is not given by the above date, the Procuring Entity will be deemed to have delayed the start of the relevant activities. The resulting adjustments in contract time to address such delay may be addressed through contract extension provided under Annex "E" of the 2016 revised IRR of RA No. 9184.

4. The Contractor's Obligations

The Contractor shall employ the key personnel named in the Schedule of Key Personnel indicating their designation, in accordance with **ITB** Clause 10.3 and specified in the **BDS**, to carry out the supervision of the Works.

The Procuring Entity will approve any proposed replacement of key personnel only if their relevant qualifications and abilities are equal to or better than those of the personnel listed in the Schedule.

5. Performance Security

- 5.1. Within ten (10) calendar days from receipt of the Notice of Award from the Procuring Entity but in no case later than the signing of the contract by both parties, the successful Bidder shall furnish the performance security in any of the forms prescribed in Section 39 of the 2016 revised IRR.
- 5.2. The Contractor, by entering into the Contract with the Procuring Entity, acknowledges the right of the Procuring Entity to institute action pursuant to RA No. 3688 against any subcontractor be they an individual, firm, partnership, corporation, or association supplying the Contractor with labor, materials and/or equipment for the performance of this Contract.

6. Site Investigation Reports

The Contractor, in preparing the Bid, shall rely on any Site Investigation Reports referred to in the SCC supplemented by any information obtained by the Contractor.

7. Warranty

- 7.1. In case the Contractor fails to undertake the repair works under Section 62.2.2 of the 2016 revised IRR, the Procuring Entity shall forfeit its performance security, subject its property(ies) to attachment or garnishment proceedings, and perpetually disqualify it from participating in any public bidding. All payables of the GOP in his favor shall be offset to recover the costs.
- 7.2. The warranty against Structural Defects/Failures, except that occasioned-on force majeure, shall cover the period from the date of issuance of the Certificate of Final Acceptance by the Procuring Entity. Specific duration of the warranty is found in the SCC.

8. Liability of the Contractor

Subject to additional provisions, if any, set forth in the SCC, the Contractor's liability under this Contract shall be as provided by the laws of the Republic of the Philippines.

If the Contractor is a joint venture, all partners to the joint venture shall be jointly and severally liable to the Procuring Entity.

9. Termination for Other Causes

Contract termination shall be initiated in case it is determined *prima facie* by the Procuring Entity that the Contractor has engaged, before, or during the implementation of the contract, in unlawful deeds and behaviors relative to contract acquisition and implementation, such as, but not limited to corrupt, fraudulent, collusive, coercive, and obstructive practices as stated in **ITB** Clause 4.

10. Dayworks

Subject to the guidelines on Variation Order in Annex “E” of the 2016 revised IRR of RA No. 9184, and if applicable as indicated in the **SCC**, the Dayworks rates in the Contractor’s Bid shall be used for small additional amounts of work only when the Procuring Entity’s Representative has given written instructions in advance for additional work to be paid for in that way.

11. Program of Work

11.1. The Contractor shall submit to the Procuring Entity’s Representative for approval the said Program of Work showing the general methods, arrangements, order, and timing for all the activities in the Works. The submissions of the Program of Work are indicated in the **SCC**.

11.2. The Contractor shall submit to the Procuring Entity’s Representative for approval an updated Program of Work at intervals no longer than the period stated in the **SCC**. If the Contractor does not submit an updated Program of Work within this period, the Procuring Entity’s Representative may withhold the amount stated in the **SCC** from the next payment certificate and continue to withhold this amount until the next payment after the date on which the overdue Program of Work has been submitted.

12. Instructions, Inspections and Audits

The Contractor shall permit the GOP or the Procuring Entity to inspect the Contractor’s accounts and records relating to the performance of the Contractor and to have them audited by auditors of the GOP or the Procuring Entity, as may be required.

13. Advance Payment

The Procuring Entity shall, upon a written request of the Contractor which shall be submitted as a Contract document, make an advance payment to the Contractor in an amount not exceeding fifteen percent (15%) of the total contract price, to be made in lump sum, or at the most two installments according to a schedule specified in the **SCC**, subject to the requirements in Annex “E” of the 2016 revised IRR of RA No. 9184.

14. Progress Payments

The Contractor may submit a request for payment for Work accomplished. Such requests for payment shall be verified and certified by the Procuring Entity’s Representative/Project Engineer. Except as otherwise stipulated in the **SCC**, materials and equipment delivered on the site but not completely put in place shall not be included for payment.

15. Operating and Maintenance Manuals

15.1. If required, the Contractor will provide “as built” Drawings and/or operating and maintenance manuals as specified in the **SCC**.

- 15.2. If the Contractor does not provide the Drawings and/or manuals by the dates stated above, or they do not receive the Procuring Entity's Representative's approval, the Procuring Entity's Representative may withhold the amount stated in the **SCC** from payments due to the Contractor.

Section V. Special Conditions of Contract

Special Conditions of Contract

GCC Clause	
2	<i>The Intended Completion Date is Thirty (30) Calendar Days from receipt of Notice to Proceed.</i>
4.1	<i>Upon receipt of the Notice to Proceed, the Contractors Representative shall immediately coordinate with the Engineering and Maintenance Division for instruction/briefing prior to implementation.</i>
6	<p>The site investigation reports are:</p> <p>⇒ <u><i>Conduct of Site Inspection is strictly required which shall be coordinated with Engr. Jose A. Ibasco.</i></u></p> <p>⇒ <i>Certificate of Site Inspection shall be issued by the CEZ Engineering & Maintenance Division and shall form part of the bidding documents.</i></p>
7.2	<p><i>The warranty against Structural Defects/Failures:</i></p> <p>Thermoplastic Paint: Six (6) months</p>
10	Dayworks are applicable at the rate shown in the Contractor's original Bid.
11.1	The Contractor shall submit the Program of Work to the Procuring Entity's Representative within <i>three (3)</i> days upon receipt of the Notice of Award.
11.2	The amount to be withheld for late submission of an updated Program of Work is [<i>insert amount</i>].
13	The amount of the advance payment <u><i>shall not exceed 15% of the total contract price and schedule of payment.</i></u>
14	Materials and equipment delivered on the site but not completely put in place shall be included for payment.
15.1	<p>The date by which operating and maintenance manuals are required is [<i>date</i>].</p> <p>The date by which "as built" drawings are required is [<i>date</i>].</p>
15.2	The amount to be withheld for failing to produce "as built" drawings and/or operating and maintenance manuals by the date required is [<i>amount in local currency</i>].

Section VI. Specifications

PROJECT : APPLICATION OF REFLECTORIZED THERMOPLASTIC PAINT
AT ROAD CENTERLINES, PEDESTRIAN LANES, YELLOW
LANES, INTERSECTIONS, AND ROAD HUMPS
LOCATION : ALONG CEZ MAIN AND MAJOR SECONDARY ROADS

A. General Requirements

1. Mobilization / Demobilization

Mobilization shall include transportation to the site of contractor's materials, equipment, employees and furnishings. Demobilization shall include removal from the site of contractor's materials and equipment. Demobilization includes clean-up of the site after completion of the contract work.

2. Temporary Facilities

The Contractor shall provide a temporary shelter but shall not be permitted to erect temporary buildings or structures inside the zone.

3. Construction Safety and Health

- The contractor shall submit appropriate Construction Safety and Health Program (CSHP) in accordance with DOLE D.O. no. 13, series of 1998.
- The contractor shall provide appropriate personal protective equipment shall not less than quantity indicated in Program of Works.

4. Project Billboard

- The contractor shall install one (1) billboard in projects site measuring 1200mmx2400mm.
- The contractor shall also install one (1) billboard as per COA circular no. 2013-004.

5. Scope

Furnish all materials, labor, equipment, tools and all other facilities for the satisfactory performance of all work necessary for the completion of the project in accordance with the plans. This project includes application of thermoplastic paints enumerated hereunder.

Main Road				
	Length (m)	Width (m)	Thickness (mm)	Area (sq.m.)
Road Centerline	1,933.25	0.20	3.20	386.65
Yellow Lanes	3,866.50	0.15	3.20	579.98
Pedestrian Lanes (14 units)	Zebra Type		3.20	267.96
Road Humps (8 units)	Yellow Thermoplastic Paint		3.20	157.76
Road Intersection (7 units)	Yellow Thermoplastic Paint		3.20	179.20
3.20				

Major Secondary Road (East, West, North, South and Rotary Avenue)				
	Length (m)	Width (m)	Thickness (mm)	Area (sq.m.)
Road Centerline	5,674.93	0.15	3.20	851.24
Yellow Lanes	10,257.82	0.15	3.20	1,538.67
Pedestrian Lanes (10 units)	Zebra Type		3.20	191.40
Road Humps (16 units)	Yellow Thermoplastic Paint		3.20	315.52
Road Intersection (12 units)	Yellow Thermoplastic Paint		3.20	307.20

5. Application Properties

- The thermoplastic material shall readily extrude at a temperature of $211 \pm 7^{\circ}\text{C}$, from approved equipment to produce a line with a minimum thickness of 3.2 mm which shall be continuous and uniform in shape having clear and sharp dimensions.
- The material shall not exude fumes which are toxic, obnoxious or injurious to persons or property when heated during application.
- The rate of application and size of glass beads for drop-on methods shall be at the option of the manufacturer/applicator, provided that all the performance requirements are met.
- The applied thermoplastic pavement markings shall have a minimum of two (2) years of longevity/durability.

6. Application Method

- a. **Preparation of Road Surface** - The materials should be applied only on the surface which is clean and dry. The use of backpack blower is required

to remove the dirt on the road surface. It shall not be laid into loose detritus, mud or similar extraneous matter or over an old thermoplastic marking which is faulty. In the case of smooth, polished surface stones such as smooth concrete, old asphalt surfacing with smooth polished surface stones and/or where the method of application of the manufacturer of the thermoplastic materials shall be recommended.

b. Preparation of Road Surface for Construction Joints

- Asphalt road construction joints – road surface shall be cleaned first using blower to remove dust and other foreign objects prior to the application of asphalt sealant to road centerlines on the asphalt roads.
- Pavement construction joints – construction joints at road centerlines along South Avenue and parts of East and Rotary Avenue shall be applied with asphalt sealant preceding to the application of primer.

c. Preparation of Thermoplastic Materials - The materials shall be melted in accordance with the manufacturer's instruction in a heater fitted with a mechanical stirrer to give a smooth consistency to the thermoplastic and such the local overheating shall be avoided. The temperature of the mass shall be within the range specified by the manufacturer and shall on no account be allowed to exceed the maximum temperature stated by the manufacturer. The molten material shall be used as expeditiously as possible and for thermoplastics which have natural resin binders or otherwise sensitive to prolong heating the materials shall not be maintained in a molten condition for more than 4 hours.

d. Laying - Center lines, lane lines and edges lines shall be applied by approved mechanical means and shall be laid in regular alignment. Other markings may be applied by hand-screed, hand propelled machine or by self-propelled machine. After transfer to the laying apparatus the materials shall be maintained within the temperature ranges specified by the manufacturer and stirred to maintain the right consistency for laying.

e. Re-use of Thermoplastic Materials - at the end of the day's as much as possible the material remaining in the heater and /or laying apparatus shall be removed. This may be broken and used again provided that the maximum heating temperature has not been exceeded and that the total time during which it is a molten condition.

7. Defective Materials or Workmanship - materials which are defective or have been applied in an unsatisfactory manner or to incorrect dimensions or in a wrong location shall be removed, the road pavement shall be made good and materials replaced, reconstructed and/or properly located, all at the Contractor's expense.

8. Protection to Traffic - the Contractor shall protect pedestrians, vehicles and other traffic adjacent to the working area against damage or disfigurement by construction equipment, tools and materials or by spatters, splashes and smirches or paint or other construction materials and during the course of the work, provide and maintain adequate signs and signals for warning and guidance of traffic.

B. Duration of Project

Completion of the project shall be 30 calendar days from the date of issuance of Notice to Proceed.

I hereby certify to comply and deliver all the above requirements.



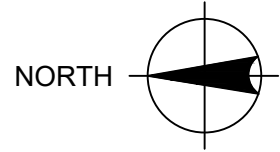

Signature over Printed Name of Representative : _____
Company/Bidder : _____
Address : _____
Tel No./E-mail Address : _____
Date : _____

Section VII. Drawings

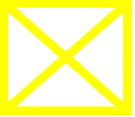

LEGEND

-  ROAD CENTERLINE
-  INTERSECTION ROAD MARKINGS
-  PEDESTRIAN LANE
-  ROAD HUMPS



1 LOCATION MAP
A-1 SCALE NTS



PROJECT TITLE
PROPOSED APPLICATION OF REFLECTORIZED THERMOPLASTIC PAINT AT ROAD CENTERLINES, PEDESTRIAN LANES, INTERSECTIONS AND ROAD HUMPS ALONG MAIN AND MAJOR SECONDARY ROADS
 LOCATION: PEZA-CEZ, ROSARIO, CAVITE

PREPARED BY
Engr. SHARAMAY S. NAVARRO
 ESO II

CHECKED BY
Engr. JOSE A. IBASCO
 OIC - EMD

RECOMMENDING APPROVAL
Engr. RONALD G. FLORES
 MANAGER, OPERATIONS DEPARTMENT



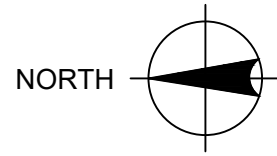

APPROVED BY
Atty. NORMA B. TAÑAG
 ZONE ADMINISTRATOR, CEZ

REVISIONS		
NO.	BY	DATE

SHEET NUMBER
A-1



LEGEND

-  ROAD CENTERLINE
-  INTERSECTION ROAD MARKINGS
-  PEDESTRIAN LANE
-  ROAD HUMPS

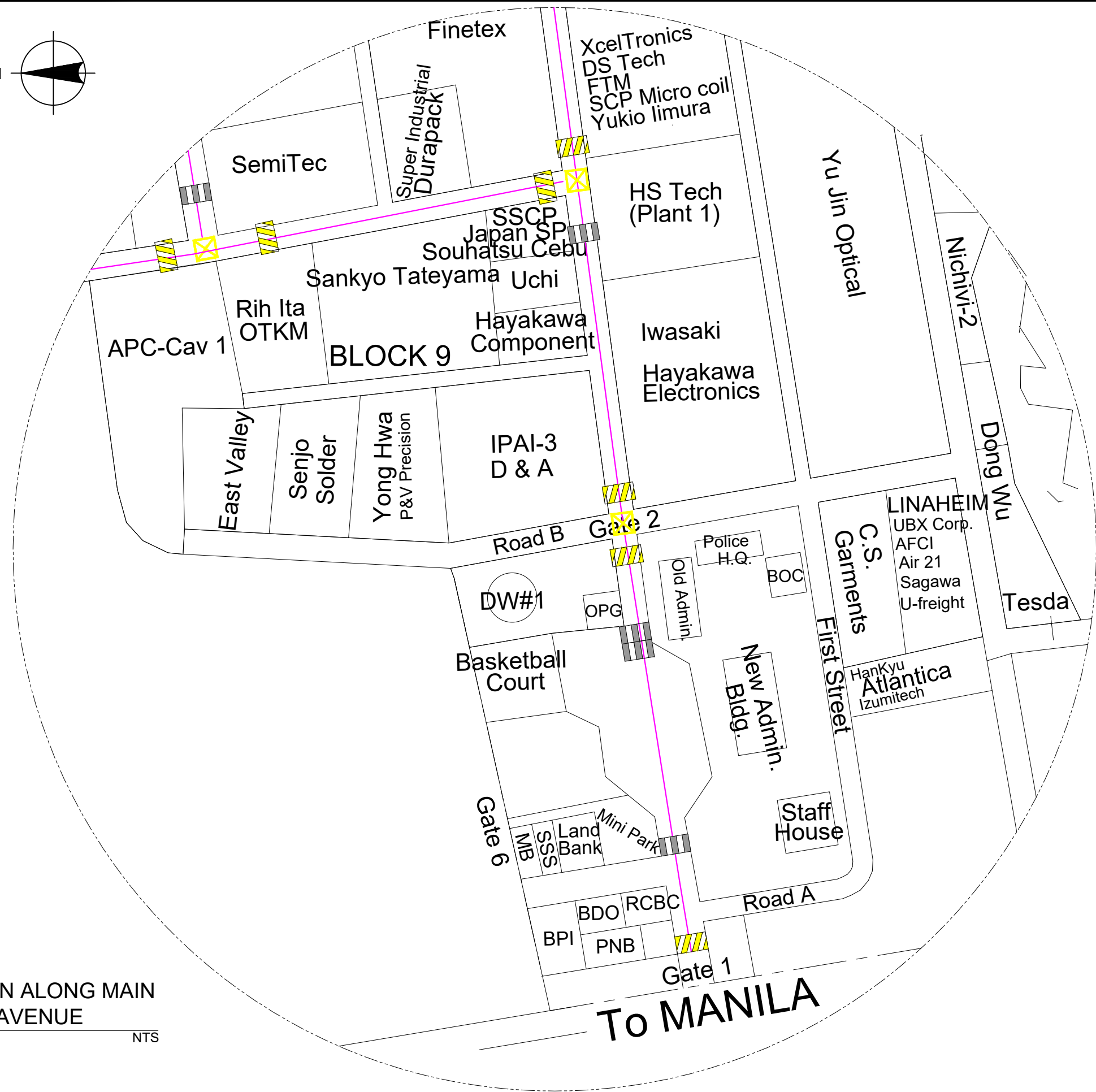

1
A-2
BLOW UP SECTION ALONG MAIN ROAD AND EAST AVENUE
SCALE NTS

TO MANILA



PROJECT TITLE
 PROPOSED APPLICATION OF REFLECTORIZED THERMOPLASTIC PAINT AT ROAD CENTERLINES, PEDESTRIAN LANES, INTERSECTIONS AND ROAD HUMPS ALONG MAIN AND MAJOR SECONDARY ROADS
 LOCATION: PEZA-CEZ, ROSARIO, CAVITE

PREPARED BY
Engr. SHARAMAY S. NAVARRO
 ESO II

CHECKED BY
Engr. JOSE A. IBASCO
 OIC - EMD

RECOMMENDING APPROVAL
Engr. RONALD G. FLORES
 MANAGER, OPERATIONS DEPARTMENT



APPROVED BY
Atty. NORMA B. TAÑAG
 ZONE ADMINISTRATOR, CEZ

REVISIONS		
NO.	BY	DATE

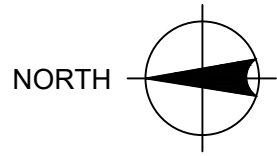
SHEET NUMBER
A-2

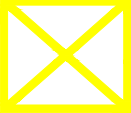

LEGEND

-  ROAD CENTERLINE
-  INTERSECTION ROAD MARKINGS
-  PEDESTRIAN LANE
-  ROAD HUMPS



BLOW UP SECTION ALONG EAST, WEST AND NORTH AVENUE

1
A-3

SCALE NTS



PROJECT TITLE
PROPOSED APPLICATION OF REFLECTORIZED THERMOPLASTIC PAINT AT ROAD CENTERLINES, PEDESTRIAN LANES, INTERSECTIONS AND ROAD HUMPS ALONG MAIN AND MAJOR SECONDARY ROADS
 LOCATION: PEZA-CEZ, ROSARIO, CAVITE

PREPARED BY
Engr. SHARAMAY S. NAVARRO
 ESO II

CHECKED BY
Engr. JOSE A. IBASCO
 OIC - EMD

RECOMMENDING APPROVAL
Engr. RONALD G. FLORES
 MANAGER, OPERATIONS DEPARTMENT



APPROVED BY
Atty. NORMA B. TAÑAG
 ZONE ADMINISTRATOR, CEZ

REVISIONS		
NO.	BY	DATE

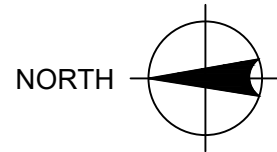
SHEET NUMBER
A-3

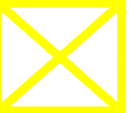
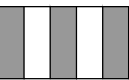

LEGEND

-  ROAD CENTERLINE
-  INTERSECTION ROAD MARKINGS
-  PEDESTRIAN LANE
-  ROAD HUMPS

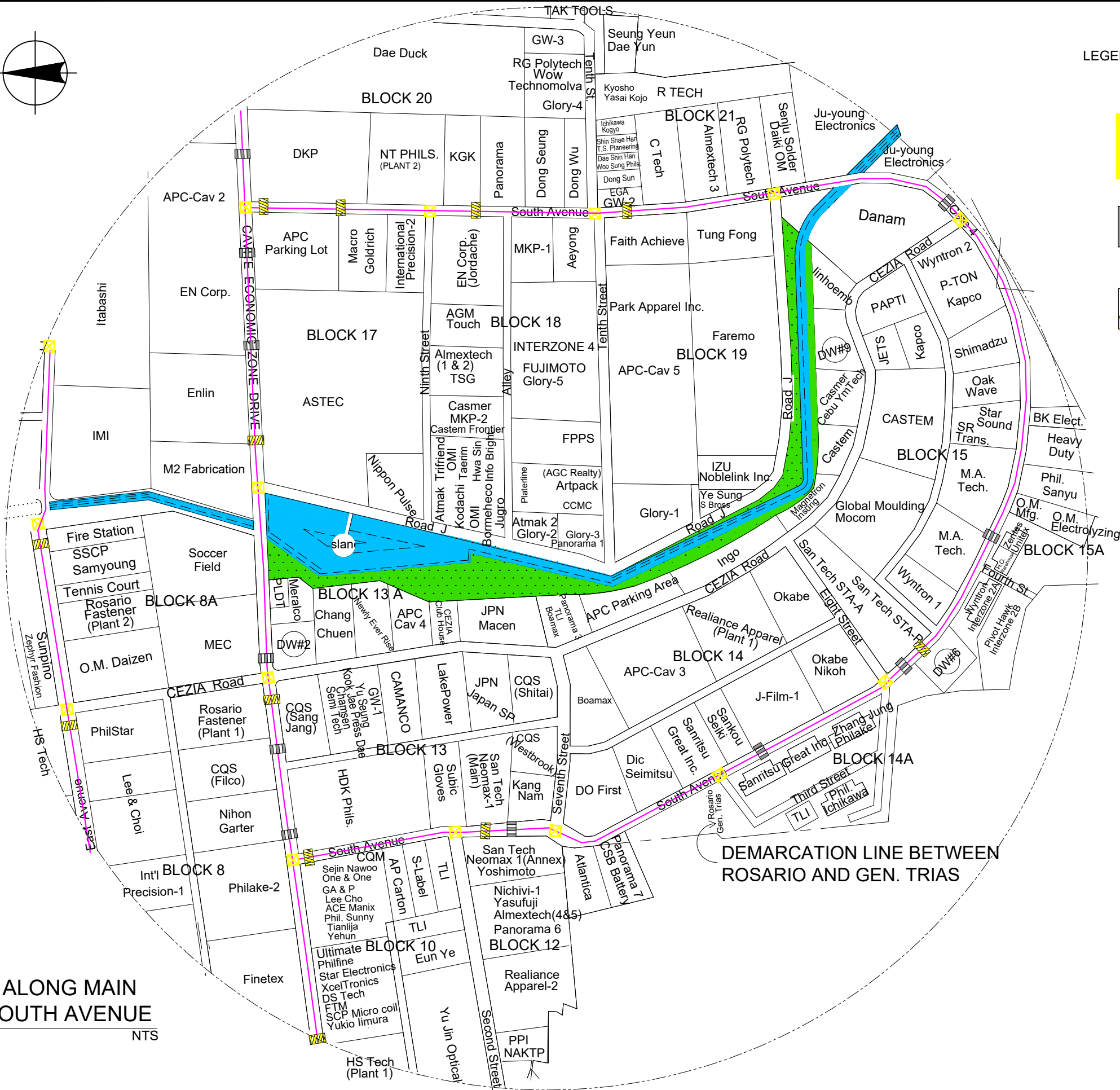

DEMARICATION LINE BETWEEN ROSARIO AND GEN. TRIAS

BLOW UP SECTION ALONG MAIN ROAD, EAST AND SOUTH AVENUE

1
A-4 SCALE



PROJECT TITLE
 PROPOSED APPLICATION OF REFLECTORIZED THERMOPLASTIC PAINT AT ROAD CENTERLINES, PEDESTRIAN LANES, INTERSECTIONS AND ROAD HUMPS ALONG MAIN AND MAJOR SECONDARY ROADS
 LOCATION: PEZA-CEZ, ROSARIO, CAVITE

PREPARED BY
Engr. SHARAMAY S. NAVARRO
 ESO II

CHECKED BY
Engr. JOSE A. IBASCO
 OIC - EMD

RECOMMENDING APPROVAL
Engr. RONALD G. FLORES
 MANAGER, OPERATIONS DEPARTMENT

APPROVED BY
Atty. NORMA B. TAÑAG
 ZONE ADMINISTRATOR, CEZ

REVISIONS		
NO.	BY	DATE

SHEET NUMBER
A-4

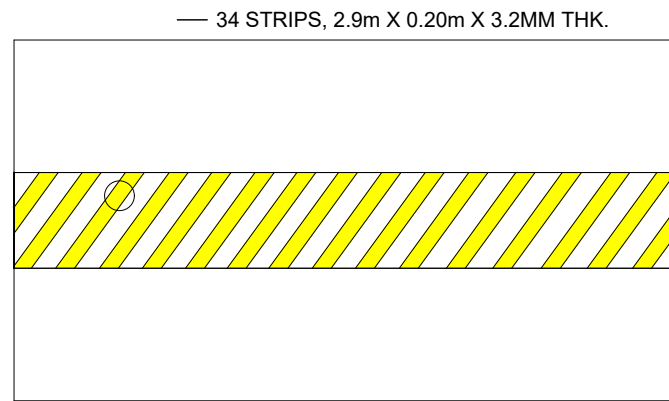

ROAD HUMPS - 24 UNITS (YELLOW THERMOPLASTIC PAINT)

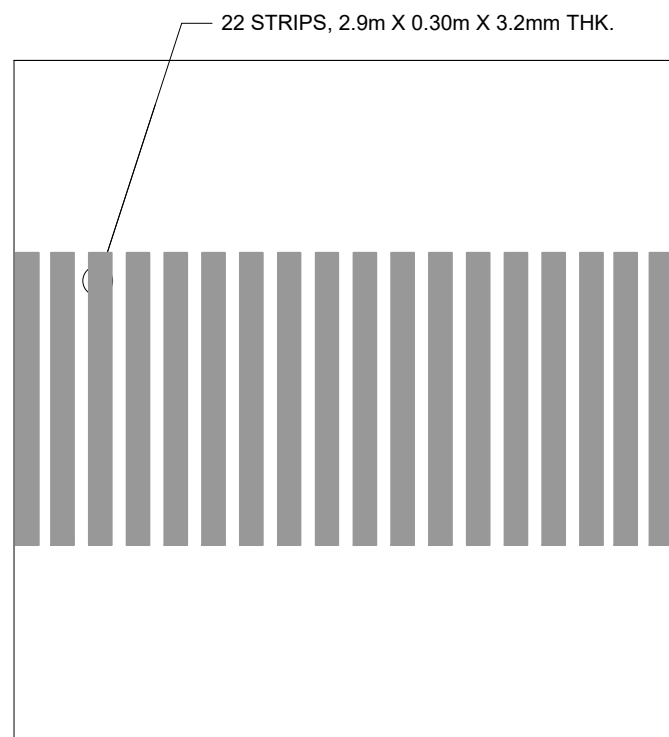

ZEBRA TYPE THERMOPLASTIC PAINT - 24 UNITS

YELLOW LANE:
L = 14,124.32m
W = 0.15m
T = 3.2mm

WHITE LANE:
L = 56,982.56m
W = 0.20m
T = 3.2mm

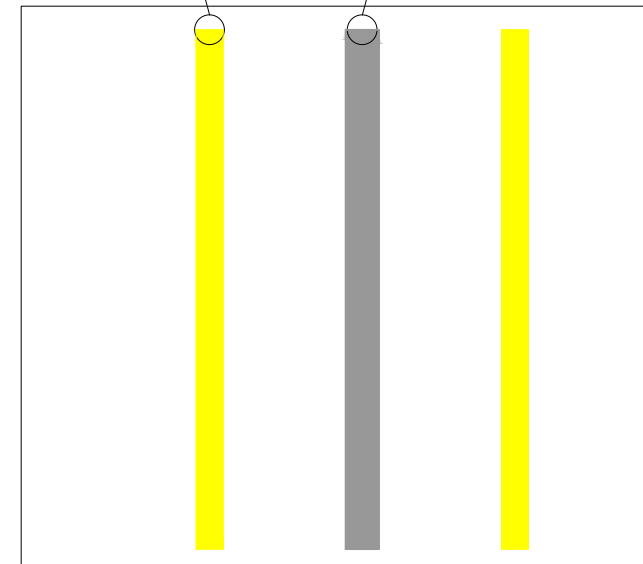

ROAD CENTERLINE MARKINGS (WHITE AND YELLOW THERMOPLASTIC PAINT)

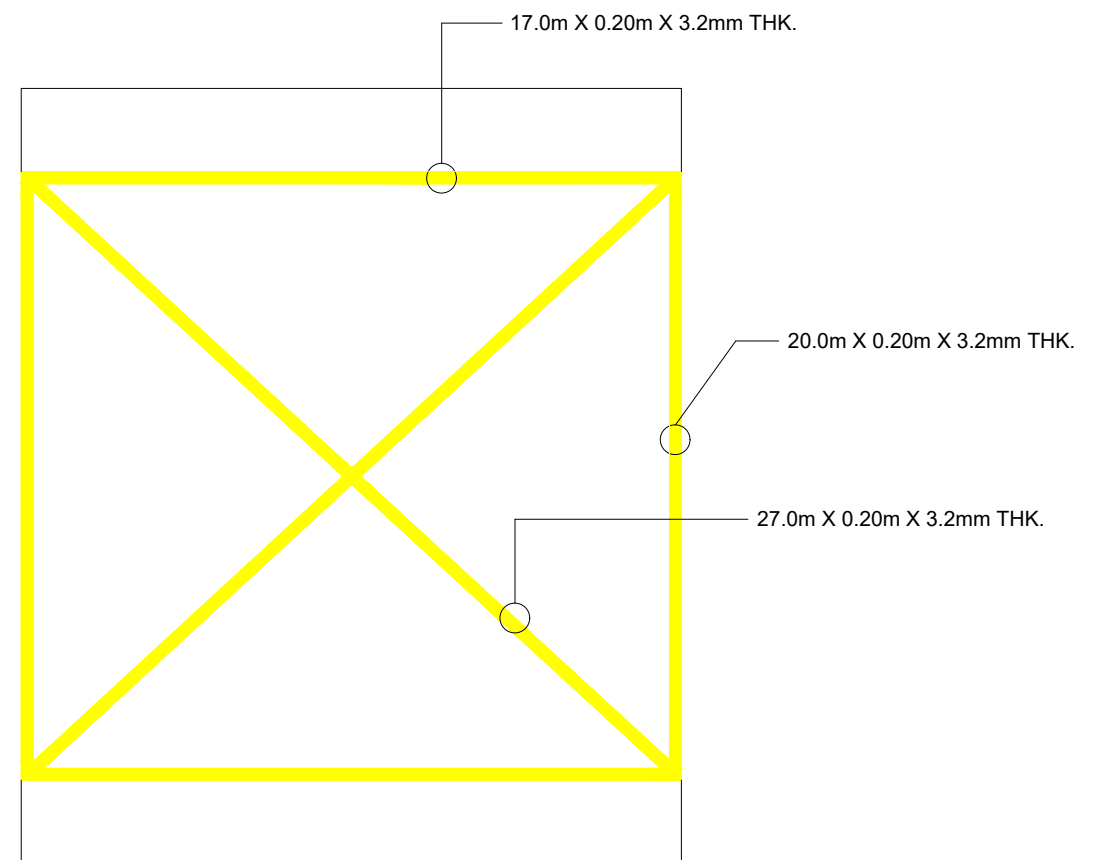

INTERSECTION ROAD MARKINGS - 19 UNITS

1
A-6

DETAILS OF REFLECTORIZED THERMOPLASTIC PAINT
SCALE NTS

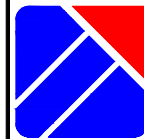
	PROJECT TITLE	PREPARED BY	CHECKED BY	RECOMMENDING APPROVAL	APPROVED BY	REVISIONS	SHEET NUMBER														
	PROPOSED APPLICATION OF REFLECTORIZED THERMOPLASTIC PAINT AT ROAD CENTERLINES, PEDESTRIAN LANES, INTERSECTIONS AND ROAD HUMPS ALONG MAIN AND MAJOR SECONDARY ROADS LOCATION: PEZA-CEZ, ROSARIO, CAVITE	Engr. SHARAMAY S. NAVARRO ESO II	Engr. JOSE A. IBASCO OIC - EMD	Engr. RONALD G. FLORES MANAGER, OPERATIONS DEPARTMENT	Atty. NORMA B. TAÑAG ZONE ADMINISTRATOR, CEZ	<table border="1"> <thead> <tr> <th>NO.</th> <th>BY</th> <th>DATE</th> </tr> </thead> <tbody> <tr><td> </td><td> </td><td> </td></tr> <tr><td> </td><td> </td><td> </td></tr> <tr><td> </td><td> </td><td> </td></tr> <tr><td> </td><td> </td><td> </td></tr> </tbody> </table>		NO.	BY	DATE											
NO.	BY	DATE																			



PHILIPPINE ECONOMIC ZONE AUTHORITY

NAME OF PROJECT:
 CONTRACTOR:
 DATE STARTED:
 CONTRACT COMPLETION DATE:
 CONTRACT COST:
 IMPLEMENTING OFFICE:

1.20

2.40

1 PROJECT BILLBOARD
 A-7 SCALE NTS



COMMISSION ON AUDIT
 PROVINCE OF CAVITE

PROJECT: COST:
 LOCATION: FUND SOURCE/S:

IMPLEMENTING AGENCY/IES: _____
 DEVELOPMENT PARTNER/S: _____
 CONTRACTOR/ SUPPLIER: _____
 BRIEF DESCRIPTION OF PROJECT: _____

PROJECT DETAILS:

PROJECT DATE		PROJECT STATUS				REMARKS	
DURATION	STARTED	TARGET DATE OF COMPLETION	PERCENTAGE OF COMPLETION	AS OF (DATE)	COST INCURRED TO DATE		DATE COMPLETED

FOR PARTICULARS OR COMPLAINTS ABOUT THIS PROJECT, PLEASE CONTACT THE REGIONAL OFFICE OR CLUSTER WHIS HAS AUDIT JURISDICTION ON THIS PROJECT:
 COA REGIONAL OFFICE NO./ CLUSTER: _____
 ADDRESS: _____
 CONTACT NO.: _____ OR TEXT COA CITIZEN'S DESK

2.40

2.40

2 COA PROJECT BILLBOARD
 A-7 SCALE NTS

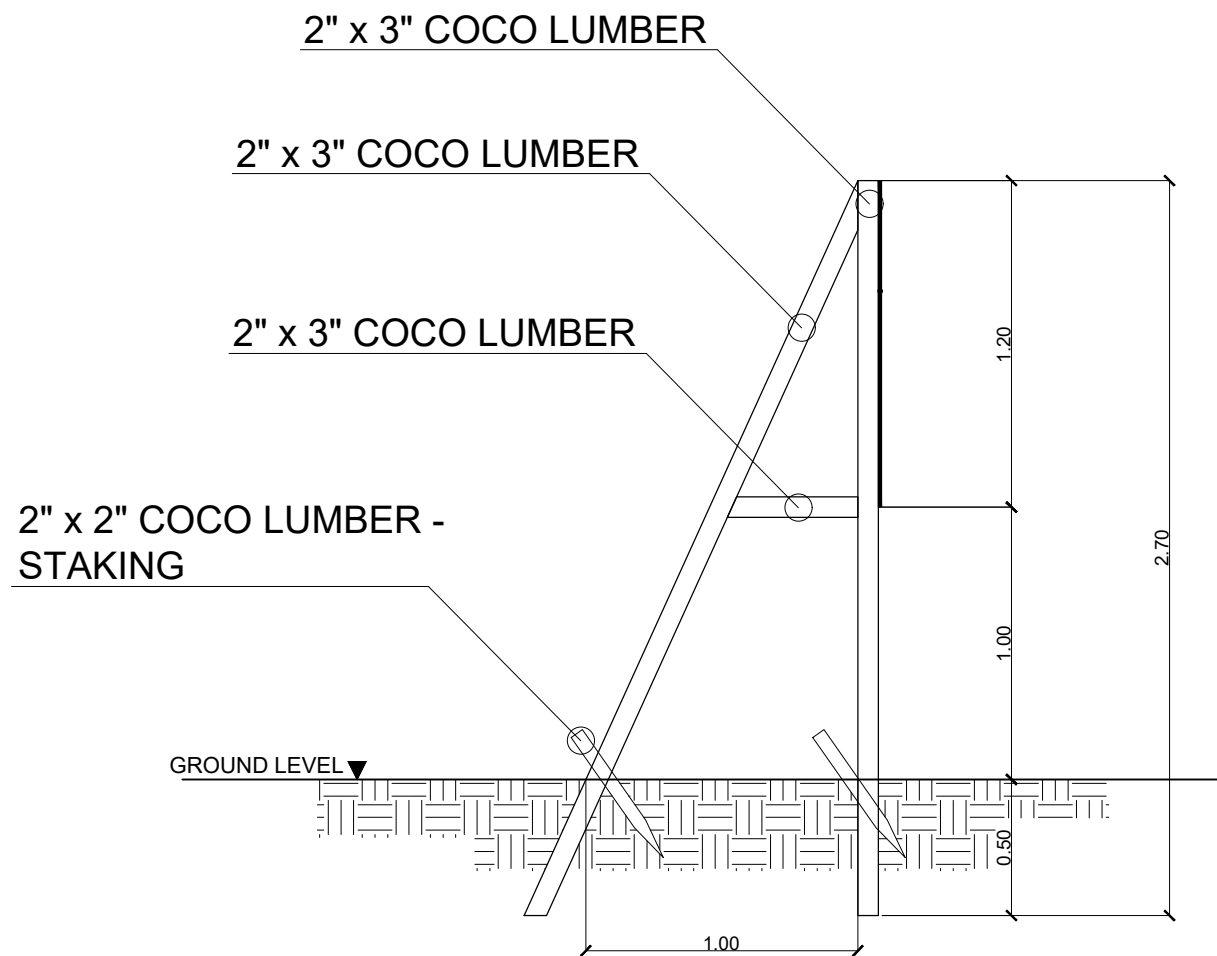

3 TYPICAL FRAME ELEVATION
 A-7 SCALE NTS

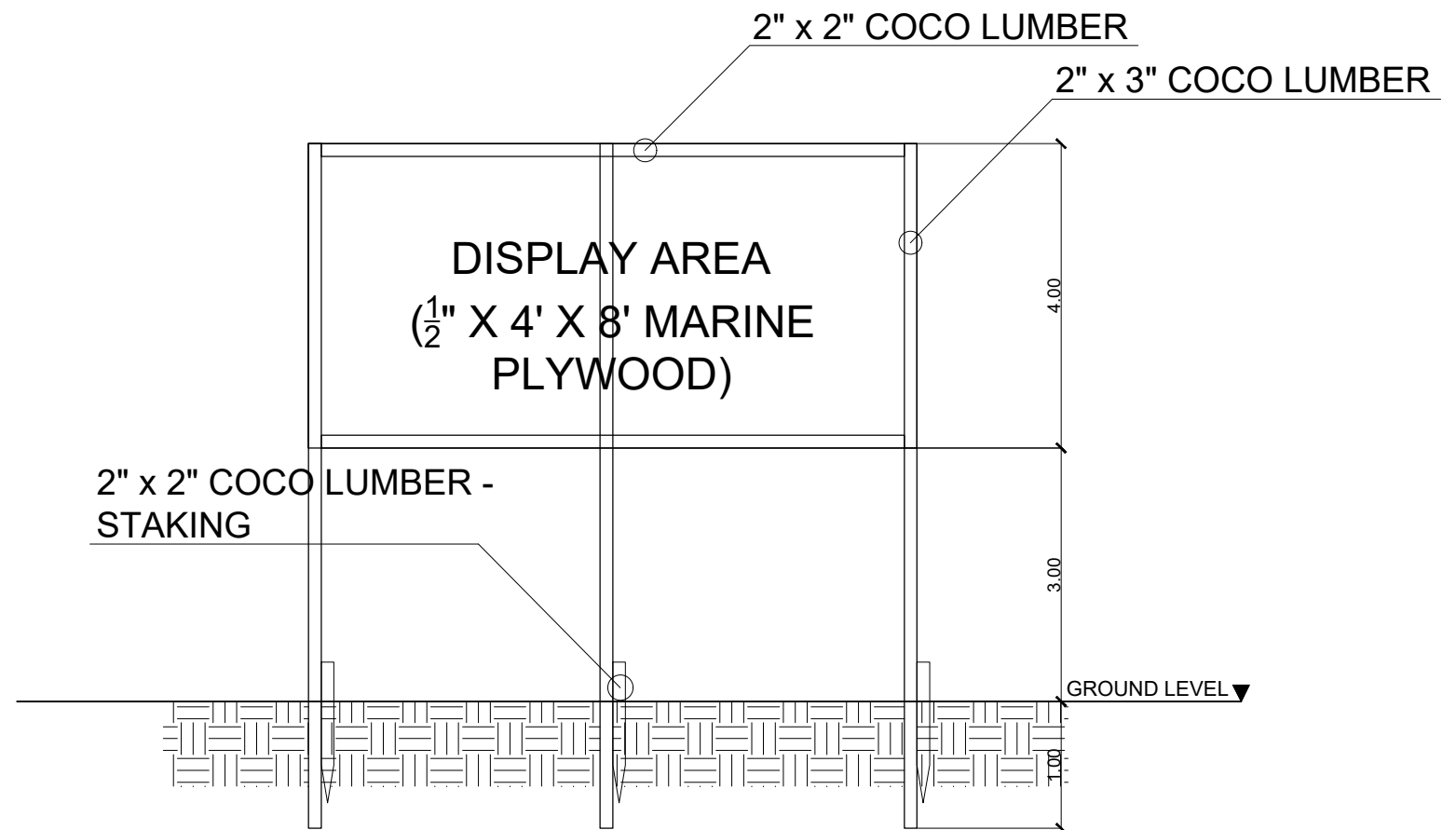

3 FRONT ELEVATION
 A-7 SCALE NTS

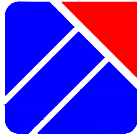
	PROJECT TITLE	PREPARED BY	CHECKED BY	RECOMMENDING APPROVAL	APPROVED BY	REVISIONS	SHEET NUMBER
	PROPOSED APPLICATION OF REFLECTORIZED THERMOPLASTIC PAINT AT ROAD CENTERLINES, PEDESTRIAN LANES, INTERSECTIONS AND ROAD HUMPS ALONG MAIN AND MAJOR SECONDARY ROADS LOCATION: PEZA-CEZ, ROSARIO, CAVITE	Engr. SHARAMAY S. NAVARRO ESO II	Engr. JOSE A. IBASCO OIC - EMD	Engr. RONALD G. FLORES MANAGER, OPERATIONS DEPARTMENT	Atty. NORMA B. TAÑAG ZONE ADMINISTRATOR, CEZ	NO. BY DATE	

Section VIII. Bill of Quantities

PHILIPPINE ECONOMIC ZONE AUTHORITY

CAVITE ECONOMIC ZONE

BILL OF QUANTITIES

NAME OF PROJECT : PROPOSED APPLICATION OF REFLECTORIZED THERMOPLASTIC PAINT AT ROAD CENTERLINES, PEDESTRIAN LANES, INTERSECTIONS AND ROAD HUMPS ALONG MAIN AND MAJOR SECONDARY ROADS AT

LOCATION : CAVITE ECONOMIC ZONE

Columns (1), (2), (3) and (4) area to be filled up by the Procuring Entity				Columns (5) and (6) are to be filled up by the Bidder	
Pay Item	Description	Quantity	Unit	Unit Price (Pesos) in Figure	Total Amount (Pesos) in Figure
-(1)	-(2)	-(3)	-(4)	-(5)	-(6)
1	Mobilization/Demobilization	1.00	l.s.		
2	Safety and Health				
	Construction Safety and Health Program	1.00	l.s.		
	Warning Signages and Project Billboard	1.00	l.s.		
3	Surface Preparation				
	Application of Asphalt Sealant	1.00	lot		
4	Road Markings				
	ReflectORIZED Thermoplastic Pavement Markings (White)	1,697.24	sq.m.		
	ReflectORIZED Thermoplastic Pavement Markings (Yellow)	3,078.33	sq.m.		
		Total Project Cost (Pesos) in Figure			
(Total Project Cost in Words)					

Submitted by:

Name and Signature of Bidder's Representative

Position

Name of Contractor

Section IX. Checklist of Technical and Financial Documents

Checklist of Technical and Financial Documents

I. TECHNICAL COMPONENT ENVELOPE

Class “A” Documents

Legal Documents

- a) Valid PhilGEPS Registration Certificate (Platinum Membership) (all pages);
and
- b) Registration certificate from Securities and Exchange Commission (SEC), Department of Trade and Industry (DTI) for sole proprietorship, or Cooperative Development Authority (CDA) for cooperatives or its equivalent document;
and
- c) Mayor’s or Business permit issued by the city or municipality where the principal place of business of the prospective bidder is located, or the equivalent document for Exclusive Economic Zones or Areas;
and
- d) Tax clearance per E.O. No. 398, s. 2005, as finally reviewed and approved by the Bureau of Internal Revenue (BIR).

Technical Documents

- e) Statement of the prospective bidder of all its ongoing government and private contracts, including contracts awarded but not yet started, if any, whether similar or not similar in nature and complexity to the contract to be bid; **and**
- f) Statement of the bidder’s Single Largest Completed Contract (SLCC) similar to the contract to be bid, except under conditions provided under the rules; **and**
- g) Philippine Contractors Accreditation Board (PCAB) License;
or
Special PCAB License in case of Joint Ventures;
and registration for the type and cost of the contract to be bid; **and**
- h) Original copy of Bid Security. If in the form of a Surety Bond, submit also a certification issued by the Insurance Commission;
or
Original copy of Notarized Bid Securing Declaration; **and**
- i) Project Requirements, which shall include the following:
 - a. Organizational chart for the contract to be bid;
 - b. List of contractor’s key personnel (*e.g.*, Project Manager, Project Engineers, Materials Engineers, and Foremen), to be assigned to the contract to be bid, with their complete qualification and experience data;
 - c. List of contractor’s major equipment units, which are owned, leased, and/or under purchase agreements, supported by proof of ownership or certification of availability of equipment from the equipment lessor/vendor for the duration of the project, as the case may be;
 - d. Certificate of Site Inspection to be issued by the CEZ Engineering and Maintenance Division representative;
 - e. Signed Specification (Section VI); **and**

- j) Original duly signed Omnibus Sworn Statement (OSS); **and** if applicable, Original Notarized Secretary's Certificate in case of a corporation, partnership, or cooperative; or Original Special Power of Attorney of all members of the joint venture giving full power and authority to its officer to sign the OSS and do acts to represent the Bidder.

Financial Documents

- k) The prospective bidder's audited financial statements, showing, among others, the prospective bidder's total and current assets and liabilities, stamped "received" by the BIR or its duly accredited and authorized institutions, for the preceding calendar year which should not be earlier than two (2) years from the date of bid submission; **and**
- l) The prospective bidder's computation of Net Financial Contracting Capacity (NFCC).

Class "B" Documents

- m) If applicable, duly signed joint venture agreement (JVA) in accordance with RA No. 4566 and its IRR in case the joint venture is already in existence; **or** duly notarized statements from all the potential joint venture partners stating that they will enter into and abide by the provisions of the JVA in the instance that the bid is successful.

II. FINANCIAL COMPONENT ENVELOPE

- n) Original of duly signed and accomplished Financial Bid Form; **and**

Other documentary requirements under RA No. 9184

- o) Original of duly signed Bid Prices in the Bill of Quantities; **and**
- p) Duly accomplished Detailed Estimates Form, including a summary sheet indicating the unit prices of construction materials, labor rates, and equipment rentals used in coming up with the Bid; **and**
- q) Cash Flow by Quarter.

Bid Form for the Procurement of Infrastructure Projects *[shall be submitted with the Bid]*

BID FORM

Date : _____
Project Identification No. : _____

To: *[name and address of Procuring Entity]*

Having examined the Philippine Bidding Documents (PBDs) including the Supplemental or Bid Bulletin Numbers *[insert numbers]*, the receipt of which is hereby duly acknowledged, we, the undersigned, declare that:

- a. We have no reservation to the PBDs, including the Supplemental or Bid Bulletins, for the Procurement Project: *[insert name of contract]*;
- b. We offer to execute the Works for this Contract in accordance with the PBDs;
- c. The total price of our Bid in words and figures, excluding any discounts offered below is: *[insert information]*;
- d. The discounts offered and the methodology for their application are: *[insert information]*;
- e. The total bid price includes the cost of all taxes, such as, but not limited to: *[specify the applicable taxes, e.g. (i) value added tax (VAT), (ii) income tax, (iii) local taxes, and (iv) other fiscal levies and duties]*, which are itemized herein and reflected in the detailed estimates,
- f. Our Bid shall be valid within the period stated in the PBDs, and it shall remain binding upon us at any time before the expiration of that period;
- g. If our Bid is accepted, we commit to obtain a Performance Security in the amount of *[insert percentage amount]* percent of the Contract Price for the due performance of the Contract, or a Performance Securing Declaration in lieu of the allowable forms of Performance Security, subject to the terms and conditions of issued GPPB guidelines¹ for this purpose;
- h. We are not participating, as Bidders, in more than one Bid in this bidding process, other than alternative offers in accordance with the Bidding Documents;
- i. We understand that this Bid, together with your written acceptance thereof included in your notification of award, shall constitute a binding contract between us, until a formal Contract is prepared and executed; and

¹ currently based on GPPB Resolution No. 09-2020

- j. We understand that you are not bound to accept the Lowest Calculated Bid or any other Bid that you may receive.
- k. We likewise certify/confirm that the undersigned, is the duly authorized representative of the bidder, and granted full power and authority to do, execute and perform any and all acts necessary to participate, submit the bid, and to sign and execute the ensuing contract for the [Name of Project] of the [Name of the Procuring Entity].
- l. We acknowledge that failure to sign each and every page of this Bid Form, including the Bill of Quantities, shall be a ground for the rejection of our bid.

Name: _____

Legal Capacity: _____

Signature: _____

Duly authorized to sign the Bid for and behalf of: _____

Date: _____

Bid Securing Declaration Form

[shall be submitted with the Bid if bidder opts to provide this form of bid security]

REPUBLIC OF THE PHILIPPINES)
CITY OF _____) S.S.

BID SECURING DECLARATION

Project Identification No.: *[Insert number]*

To: *[Insert name and address of the Procuring Entity]*

I/We, the undersigned, declare that:

1. I/We understand that, according to your conditions, bids must be supported by a Bid Security, which may be in the form of a Bid Securing Declaration.
2. I/We accept that: (a) I/we will be automatically disqualified from bidding for any procurement contract with any procuring entity for a period of two (2) years upon receipt of your Blacklisting Order; and, (b) I/we will pay the applicable fine provided under Section 6 of the Guidelines on the Use of Bid Securing Declaration, within fifteen (15) days from receipt of the written demand by the procuring entity for the commission of acts resulting to the enforcement of the bid securing declaration under Sections 23.1(b), 34.2, 40.1 and 69.1, except 69.1(f), of the IRR of RA No. 9184; without prejudice to other legal action the government may undertake.
3. I/We understand that this Bid Securing Declaration shall cease to be valid on the following circumstances:
 - a. Upon expiration of the bid validity period, or any extension thereof pursuant to your request;
 - b. I am/we are declared ineligible or post-disqualified upon receipt of your notice to such effect, and (i) I/we failed to timely file a request for reconsideration or (ii) I/we filed a waiver to avail of said right; and
 - c. I am/we are declared the bidder with the Lowest Calculated Responsive Bid, and I/we have furnished the performance security and signed the Contract.

IN WITNESS WHEREOF, I/We have hereunto set my/our hand/s this ____ day of *[month]* *[year]* at *[place of execution]*.

[Insert NAME OF BIDDER OR ITS AUTHORIZED REPRESENTATIVE]

[Insert signatory's legal capacity]

Affiant

[Format shall be based on the latest Rules on Notarial Practice]

Omnibus Sworn Statement (Revised)
[shall be submitted with the Bid]

REPUBLIC OF THE PHILIPPINES)
CITY/MUNICIPALITY OF _____) S.S.

AFFIDAVIT

I, [Name of Affiant], of legal age, [Civil Status], [Nationality], and residing at [Address of Affiant], after having been duly sworn in accordance with law, do hereby depose and state that:

1. *[Select one, delete the other:]*

[If a sole proprietorship:] I am the sole proprietor or authorized representative of [Name of Bidder] with office address at [address of Bidder];

[If a partnership, corporation, cooperative, or joint venture:] I am the duly authorized and designated representative of [Name of Bidder] with office address at [address of Bidder];

2. *[Select one, delete the other:]*

[If a sole proprietorship:] As the owner and sole proprietor, or authorized representative of [Name of Bidder], I have full power and authority to do, execute and perform any and all acts necessary to participate, submit the bid, and to sign and execute the ensuing contract for [Name of the Project] of the [Name of the Procuring Entity], as shown in the attached duly notarized Special Power of Attorney;

[If a partnership, corporation, cooperative, or joint venture:] I am granted full power and authority to do, execute and perform any and all acts necessary to participate, submit the bid, and to sign and execute the ensuing contract for [Name of the Project] of the [Name of the Procuring Entity], as shown in the attached [state title of attached document showing proof of authorization (e.g., duly notarized Secretary's Certificate, Board/Partnership Resolution, or Special Power of Attorney, whichever is applicable)];

3. [Name of Bidder] is not "blacklisted" or barred from bidding by the Government of the Philippines or any of its agencies, offices, corporations, or Local Government Units, foreign government/foreign or international financing institution whose blacklisting rules have been recognized by the Government Procurement Policy Board, **by itself or by relation, membership, association, affiliation, or controlling interest with another blacklisted person or entity as defined and provided for in the Uniform Guidelines on Blacklisting;**

4. Each of the documents submitted in satisfaction of the bidding requirements is an authentic copy of the original, complete, and all statements and information provided therein are true and correct;

5. [Name of Bidder] is authorizing the Head of the Procuring Entity or its duly authorized representative(s) to verify all the documents submitted;

6. *[Select one, delete the rest:]*

[If a sole proprietorship:] The owner or sole proprietor is not related to the Head of the Procuring Entity, members of the Bids and Awards Committee (BAC), the Technical Working Group, and the BAC Secretariat, the head of the Project Management Office or the end-user unit, and the project consultants by consanguinity or affinity up to the third civil degree;

[If a partnership or cooperative:] None of the officers and members of *[Name of Bidder]* is related to the Head of the Procuring Entity, members of the Bids and Awards Committee (BAC), the Technical Working Group, and the BAC Secretariat, the head of the Project Management Office or the end-user unit, and the project consultants by consanguinity or affinity up to the third civil degree;

[If a corporation or joint venture:] None of the officers, directors, and controlling stockholders of *[Name of Bidder]* is related to the Head of the Procuring Entity, members of the Bids and Awards Committee (BAC), the Technical Working Group, and the BAC Secretariat, the head of the Project Management Office or the end-user unit, and the project consultants by consanguinity or affinity up to the third civil degree;

7. *[Name of Bidder]* complies with existing labor laws and standards; and
8. *[Name of Bidder]* is aware of and has undertaken the responsibilities as a Bidder in compliance with the Philippine Bidding Documents, which includes:
 - a. Carefully examining all of the Bidding Documents;
 - b. Acknowledging all conditions, local or otherwise, affecting the implementation of the Contract;
 - c. Making an estimate of the facilities available and needed for the contract to be bid, if any; and
 - d. Inquiring or securing Supplemental/Bid Bulletin(s) issued for the *[Name of the Project]*.
9. *[Name of Bidder]* did not give or pay directly or indirectly, any commission, amount, fee, or any form of consideration, pecuniary or otherwise, to any person or official, personnel or representative of the government in relation to any procurement project or activity.
10. **In case advance payment was made or given, failure to perform or deliver any of the obligations and undertakings in the contract shall be sufficient grounds to constitute criminal liability for Swindling (Estafa) or the commission of fraud with unfaithfulness or abuse of confidence through misappropriating or converting any payment received by a person or entity under an obligation involving the duty to deliver certain goods or services, to the prejudice of the public and the government of the Philippines pursuant to Article 315 of Act No. 3815 s. 1930, as amended, or the Revised Penal Code.**

IN WITNESS WHEREOF, I have hereunto set my hand this ___ day of ___, 20__ at _____, Philippines.

[Insert NAME OF BIDDER OR ITS AUTHORIZED REPRESENTATIVE]
[Insert signatory's legal capacity]
Affiant

[Jurat]

[Format shall be based on the latest Rules on Notarial Practice]

**Contract Agreement Form for the
Procurement of Infrastructure Projects (Revised)**

[not required to be submitted with the Bid, but it shall be submitted within ten (10) days after receiving the Notice of Award]

CONTRACT AGREEMENT

THIS AGREEMENT, made this *[insert date]* day of *[insert month]*, *[insert year]* between *[name and address of PROCURING ENTITY]* (hereinafter called the "Entity") and *[name and address of Contractor]* (hereinafter called the "Contractor").

WHEREAS, the Entity is desirous that the Contractor execute *[name and identification number of contract]* (hereinafter called "the Works") and the Entity has accepted the Bid for *[contract price in words and figures in specified currency]* by the Contractor for the execution and completion of such Works and the remedying of any defects therein.

NOW THIS AGREEMENT WITNESSETH AS FOLLOWS:

1. In this Agreement, words and expressions shall have the same meanings as are respectively assigned to them in the Conditions of Contract hereinafter referred to.
2. The following documents as required by the 2016 revised Implementing Rules and Regulations of Republic Act No. 9184 shall be deemed to form and be read and construed as part of this Agreement, viz.:
 - a. Philippine Bidding Documents (PBDs);
 - i. Drawings/Plans;
 - ii. Specifications;
 - iii. Bill of Quantities;
 - iv. General and Special Conditions of Contract;
 - v. Supplemental or Bid Bulletins, if any;
 - b. Winning bidder's bid, including the Eligibility requirements, Technical and Financial Proposals, and all other documents or statements submitted;

Bid form, including all the documents/statements contained in the Bidder's bidding envelopes, as annexes, and all other documents submitted (e.g., Bidder's response to request for clarifications on the bid), including corrections to the bid, if any, resulting from the Procuring Entity's bid evaluation;

- c. Performance Security;
- d. Notice of Award of Contract and the Bidder's conforme thereto; and
- e. Other contract documents that may be required by existing laws and/or the Procuring Entity concerned in the PBDs. **Winning bidder agrees that additional contract documents or information prescribed by the GPPB that are subsequently required for submission after the contract execution, such as the Notice to Proceed, Variation Orders, and Warranty Security, shall likewise form part of the Contract.**

3. In consideration for the sum of *[total contract price in words and figures]* or such other sums as may be ascertained, *[Named of the bidder]* agrees to *[state the object of the contract]* in accordance with his/her/its Bid.
4. The *[Name of the procuring entity]* agrees to pay the above-mentioned sum in accordance with the terms of the Bidding.

IN WITNESS whereof the parties thereto have caused this Agreement to be executed the day and year first before written.

[Insert Name and Signature]

[Insert Name and Signature]

[Insert Signatory's Legal Capacity]

[Insert Signatory's Legal Capacity]

for:

for:

[Insert Procuring Entity]

[Insert Name of Supplier]

Acknowledgment

[Format shall be based on the latest Rules on Notarial Practice]

Performance Securing Declaration (Revised)

[if used as an alternative performance security but it is not required to be submitted with the Bid, as it shall be submitted within ten (10) days after receiving the Notice of Award]

REPUBLIC OF THE PHILIPPINES)
CITY OF _____) S.S.

PERFORMANCE SECURING DECLARATION

Invitation to Bid: [Insert Reference Number indicated in the Bidding Documents]

To: [Insert name and address of the Procuring Entity]

I/We, the undersigned, declare that:

1. I/We understand that, according to your conditions, to guarantee the faithful performance by the supplier/distributor/manufacturer/contractor/consultant of its obligations under the Contract, I/we shall submit a Performance Securing Declaration within a maximum period of ten (10) calendar days from the receipt of the Notice of Award prior to the signing of the Contract.
2. I/We accept that: I/we will be automatically disqualified from bidding for any procurement contract with any procuring entity for a period of one (1) year for the first offense, or two (2) years **for the second offense**, upon receipt of your Blacklisting Order if I/We have violated my/our obligations under the Contract;
3. I/We understand that this Performance Securing Declaration shall cease to be valid upon:
 - a. issuance by the Procuring Entity of the Certificate of Final Acceptance, subject to the following conditions:
 - i. Procuring Entity has no claims filed against the contract awardee;
 - ii. It has no claims for labor and materials filed against the contractor; and
 - iii. Other terms of the contract; or
 - b. replacement by the winning bidder of the submitted PSD with a performance security in any of the prescribed forms under Section 39.2 of the 2016 revised IRR of RA No. 9184 as required by the end-user.

IN WITNESS WHEREOF, I/We have hereunto set my/our hand/s this ____ day of [month] [year] at [place of execution].

*[Insert NAME OF BIDDER OR ITS
AUTHORIZED REPRESENTATIVE]*

[Insert signatory's legal capacity]

Affiant

[Jurat]

[Format shall be based on the latest Rules on Notarial Practice]

APPLICATION OF REFLECTORIZED THERMOPLASTIC PAINT AT ROAD CENTERLINES, PEDESTRIAN LANES, YELLOW LANES, INTERSECTIONS, AND ROAD HUMPS ALONG CEZ MAIN AND MAJOR SECONDARY ROADS
Reference No. CEZITB 2021-04-008

List of all Ongoing Government & Private Contracts including contracts awarded but not yet started

Business Name : _____

Business Address : _____

Name of Contract	a. End-User's Name	Nature of Work	a. Date Awarded	Amount of Contract	Value of Outstanding Works/Undelivered Portion
	b. Address		b. Date Started		
	c. Telephone Nos.				
<u>Government</u>					
<u>Private</u>					
				Total Cost	

Submitted by : _____
(Printed Name & Signature)

Designation : _____

Date : _____

Instructions:

1. State all ongoing contracts including those awarded but not yet started (government and private contracts which may be similar or not similar to the project to be bid;
2. If there is no ongoing contracts including those awarded but not yet started as of the aforementioned period, state none or equivalent terms;
3. The total amount of the ongoing and awarded but not yet started contract should be consistent with those used in the Net Financial Contracting Capacity (NFCC).

PHILIPPINE ECONOMIC ZONE AUTHORITY

APPLICATION OF REFLECTORIZED THERMOPLASTIC PAINT AT ROAD CENTERLINES, PEDESTRIAN LANES, YELLOW LANES, INTERSECTIONS, AND ROAD HUMPS ALONG CEZ MAIN AND MAJOR SECONDARY ROADS
 Reference No. CEZITB 2021-04-008

Statement of Single Largest Completed Contract which is similar in nature

Business Name : _____

Business Address : _____

Name of Contract	a. End-User's Name	Date of Contract	Contract Duration	Nature of Work	Amount of Contract	Date Completed/End-Users Acceptance
	b. Address					
	c. Telephone Nos.					
<u>Government</u>						
<u>Private</u>						

Note: This matrix shall be supported with the following documents:

1. NOA / NTP / Contract
2. Certificate of Completion and Acceptance or CPES Rating
3. Official Receipts for Private Contracts

Submitted by : _____
 (Printed Name & Signature)

Designation : _____

Date : _____

Instruction:

- a) state the single largest completed contract (government or private) within the last five (5) years prior to bid opening.

Statement of Availability of Key Personnel and Equipment

(Date of Issuance)

Levi D. Vizmanos

Chairperson
Bids and Awards Committee (BAC)
PEZA – Cavite Economic Zone
Rosario, Cavite

Dear Sir:

In compliance with the requirements of the **PEZA - Cavite Economic Zone** for the bidding of the project “**Application of ReflectORIZED Thermoplastic Paint at Road Centerlines, Pedestrian Lanes, Yellow Lanes, Intersections, and Road Humps along CEZ Main and Major Secondary Roads (CEZITB 2021-04-008)**”, we certify that **(Name of the Bidder)** has in its employ key personnel, such as project managers, project engineers, materials engineer and foreman, who may be engaged in the implementation of the said contract.

Further, we likewise certify the availability of equipment that **(Name of the Bidder)** owns, has under lease, and / or has under purchase agreements, which may be used for the contract.

Very truly yours,

(Name of Representative)

(Position)

(Name of Bidder)

Philippine Economic Zone Authority – CEZ

Application of Reflectorized Thermoplastic Paint at Road Centerlines, Pedestrian Lanes, Yellow Lanes, Intersections, and Road Humps along CEZ Main and Major Secondary Roads (CEZITB 2021-04-008)

Qualification of Key Personnel Proposed to be Assigned to the Contract

Business Name : _____
 Business Address : _____

	Project Manager	Project Engineers	Materials Engineers	Foremen	Other position deemed needed in the project
1 Name					
2 Address					
3 Date of Birth					
4 Employed Since					
5 Experience					
6 Previous Employment					
7 Education					
8 PRC License					

Note: Attach individual biodata / resume and PRC License of the (Professional) Personnel

Bidder's Representative : _____
 (Printed Name and Signature)

Designation : _____

Date : _____

Philippine Economic Zone Authority – CEZ

Application of Reflectorized Thermoplastic Paint at Road Centerlines, Pedestrian Lanes, Yellow Lanes, Intersections, and Road Humps along CEZ Main and Major Secondary Roads (CEZITB 2021-04-008)

List of Equipment Owned / Leased and/or under purchase agreements, assigned to the Proposed Contract

Bidder's Name : _____

Bidder's Address : _____

Description	Model / Year	Capacity / Performance / Size	Plate No.	Motor No. / Body No.	Location	Condition	Proof of Ownership
A. Owned							
1.							
2.							
3.							
B. Leased							
1.							
2.							
3.							
C. Under Purchase Agreement							
1.							
2.							
3.							

Bidder's Representative : _____

(Printed Name and Signature)

Designation : _____

Date : _____

